

User Guide

EVB-ATEK252P3-01

Document Code : 023-01004202
Revision No : 01
Revision Date : 14/07/2021

Revisions

Revision No	Revision Date	Revision Reason	Section / Page No
1.0	14.07.2021	Initial Version	

INDEX

1 GENERAL INFORMATION 3

2 DESIGN INFORMATION 4

2.1 SCHEMATIC 4

2.2 BOM 4

3 TYPICAL PERFORMANCE PLOTS..... 5

1 GENERAL INFORMATION

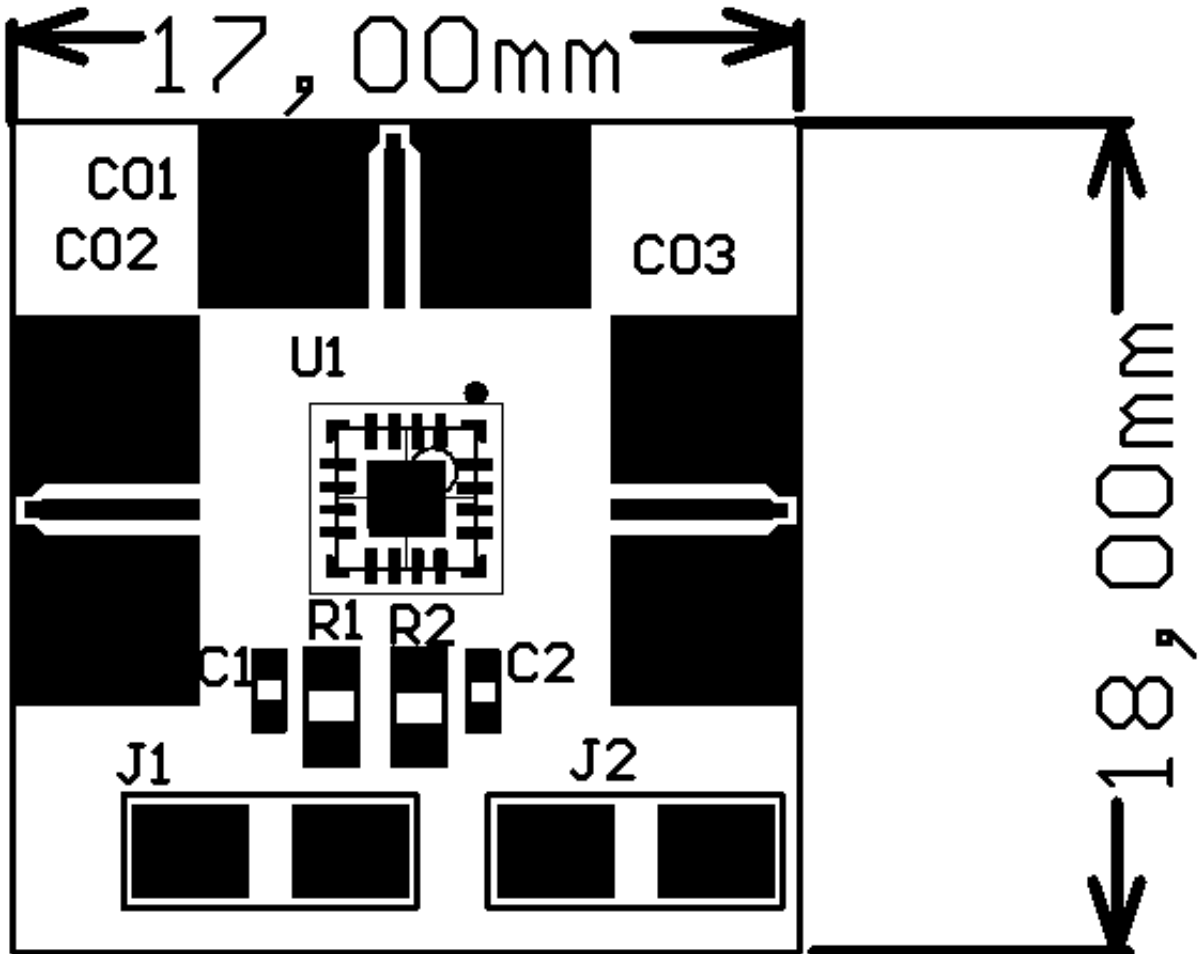

PIN Name	Definition	Comment
CO1	RF IN	K Connector
CO2, CO3	RF OUT	K Connector
J1 Left	CTRL B	2.54mm Header
J1 Right	CTRL A	2.54mm Header
J2 Left	N/A	2.54mm Header
J2 Right	GND	2.54mm Header

Notes:

1. VDD Voltage is detailed in Datasheet.
2. Control Voltage is detailed in Datasheet.
3. The definition of up, down, right, and left is valid for this view of PCB.

2 DESIGN INFORMATION

2.1 SCHEMATIC

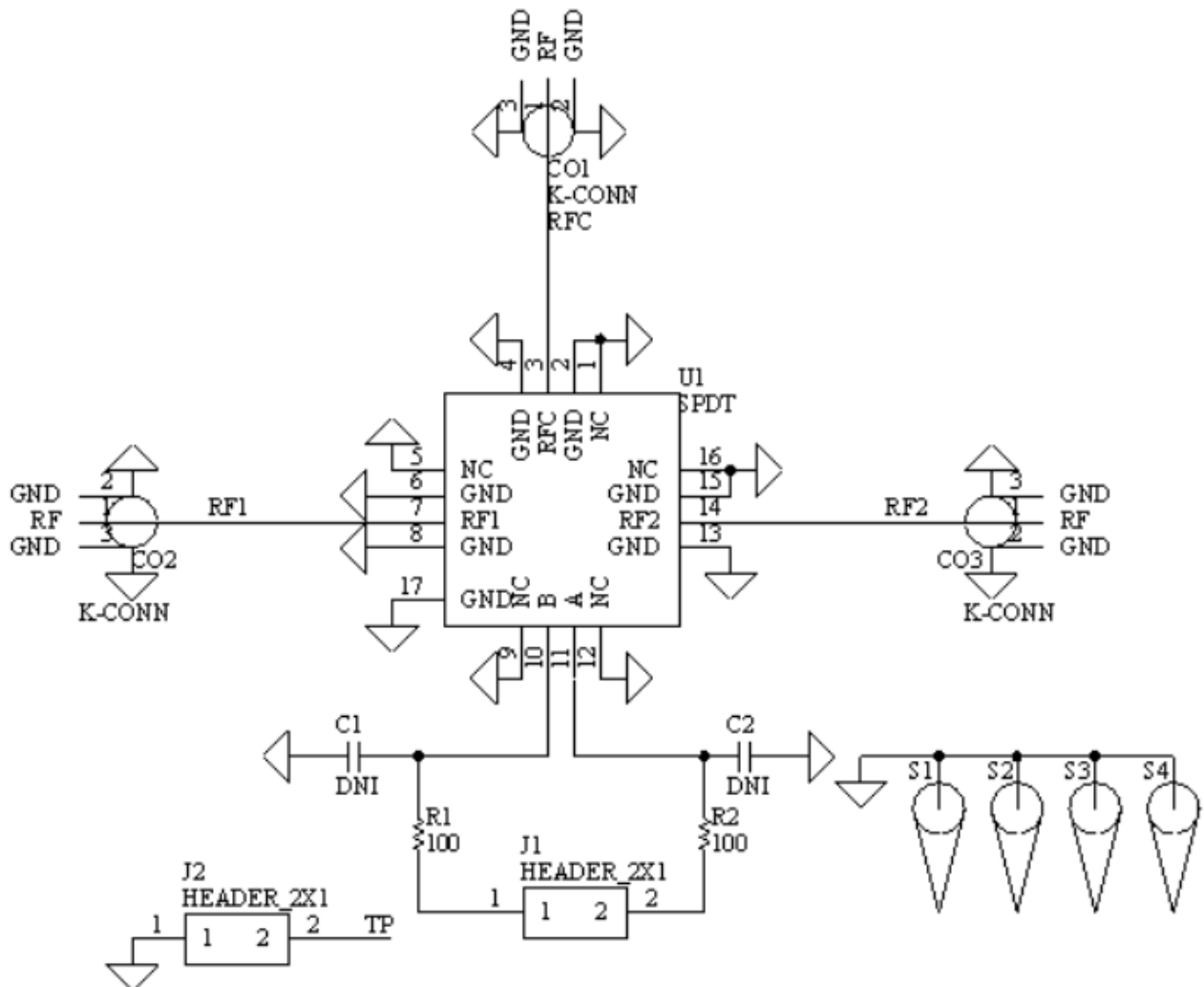

2.2 BOM

Designator	Footprint	Qty	Comment	PN
CO1, CO2, CO3	K Connector	3	K Connector	96-02-5M2-037A
J1, J2	HEADER_2X1_V2	2	HEADER_2X1	
R1, R2	0603	2	OR	
U1	ATEKQ3316	1	SPDT	ATEK252 P42

3 TYPICAL PERFORMANCE PLOTS

Conditions unless otherwise specified: $V_{CTRL} = 0/-5\text{ V}$, $T = 25\text{ C}$, CW. For details, please refer to the datasheet.

Insertion Loss

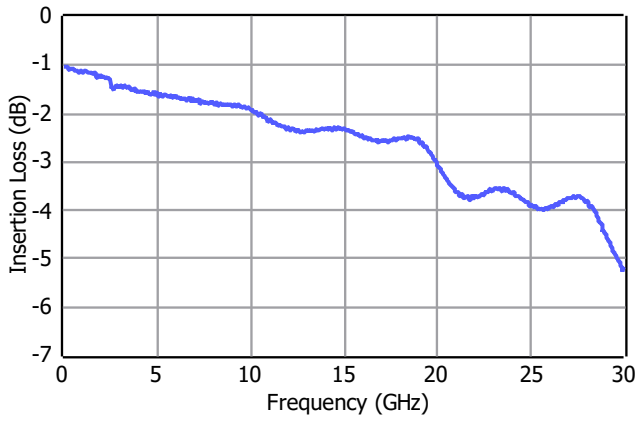

Return Loss

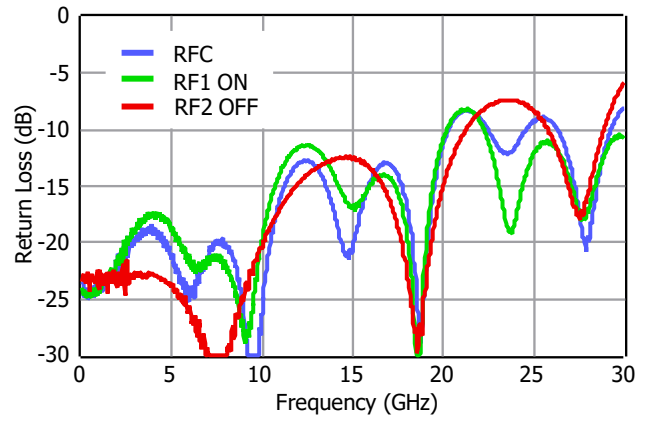

Isolation from RFC to RF2

