



User Guide

EVB-ATEK252P3-03

Document Code : 023-134201
Revision No : 01
Revision Date : 16/06/2022

Revisions

Revision No	Revision Date	Revision Reason	Section / Page No
1.0	16.06.2022	Initial Release	

INDEX

1	GENERAL INFORMATION	3
2	DESIGN INFORMATION	4
2.1	SCHEMATIC	4
2.2	BOM	4
3	TYPICAL PERFORMANCE PLOTS.....	5

1 GENERAL INFORMATION

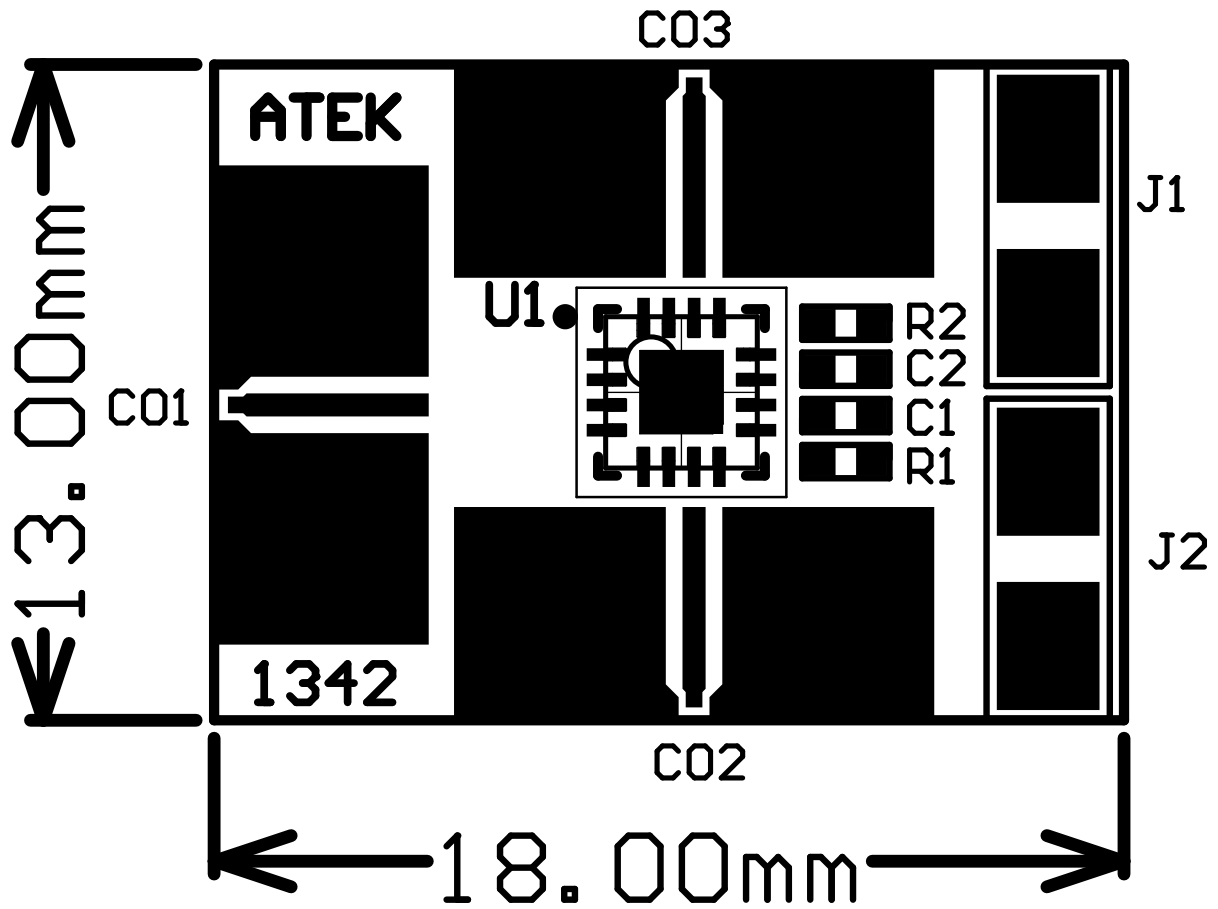

PIN Name	Definition	Comment
C01	RF IN	K Connector
C02, C03	RF OUT	K Connector
J1 Up	CTRL A	2.54mm Header
J1 Down	CTRL B	2.54mm Header
J2 Up	N/A	2.54mm Header
J2 Down	GND	2.54mm Header

Notes:

1. VDD Voltage is detailed in Datasheet.
2. Control Voltages are detailed in Datasheet.
3. The definition of up, down, right, and left is valid for this view of PCB.

2 DESIGN INFORMATION

2.1 SCHEMATIC

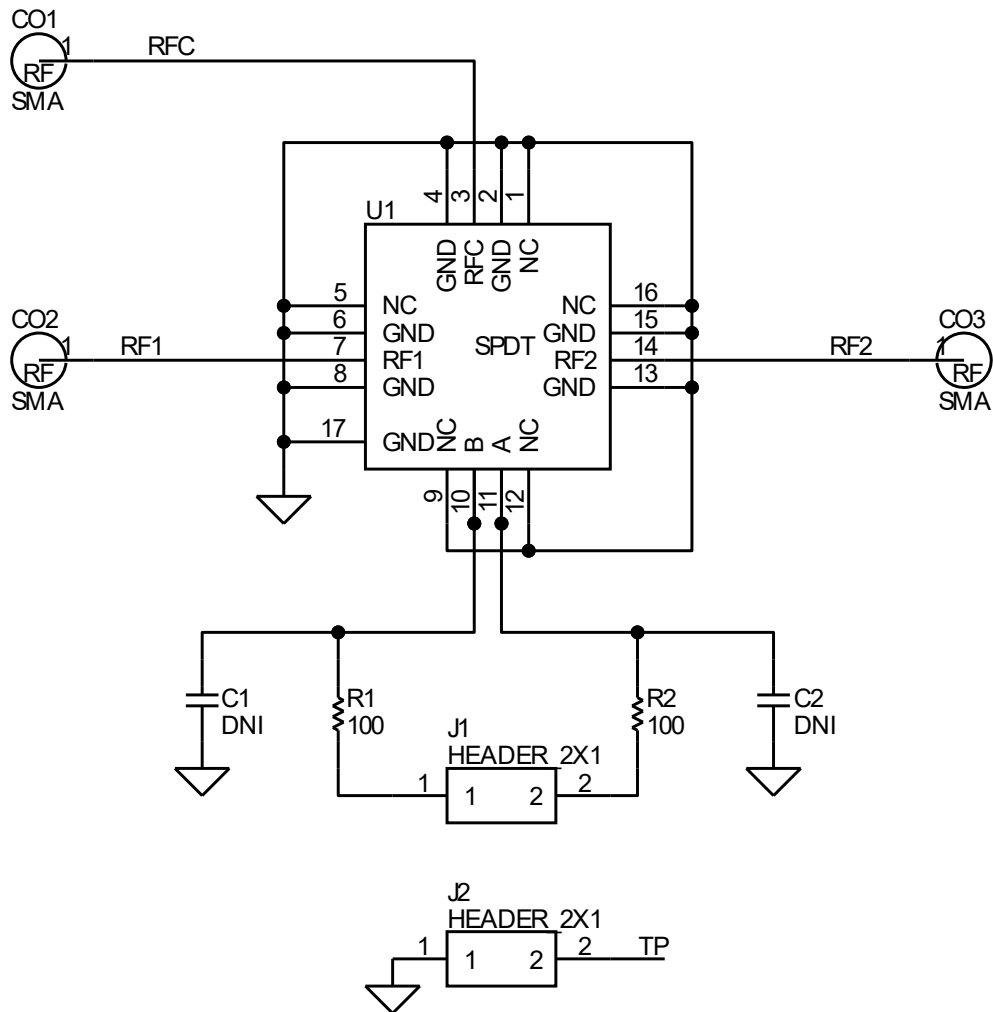

2.2 BOM

Designator	Footprint	Qty	Comment	PN
C1, C2	0402	2	DNP	
CO1, CO2, CO3	K Connector	3	K Connector	ATEK9292
J1, J2	2x1 Header	2	2x1 Header	
R1, R2	0402	2	OR	
U1	ATEKQ3316	1	SPDT	ATEK252P3

3 TYPICAL PERFORMANCE PLOTS

Conditions unless otherwise specified: $V_{CTRL} = 0/-5\text{ V}$, $T = 25\text{ C}$, CW. For details, please refer to the datasheet.

Insertion Loss

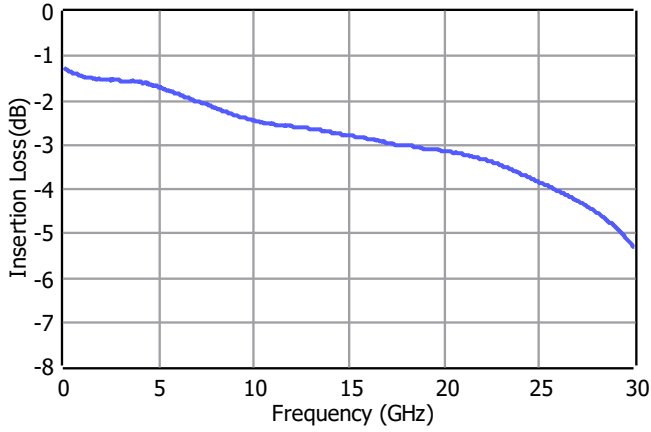

Return Loss

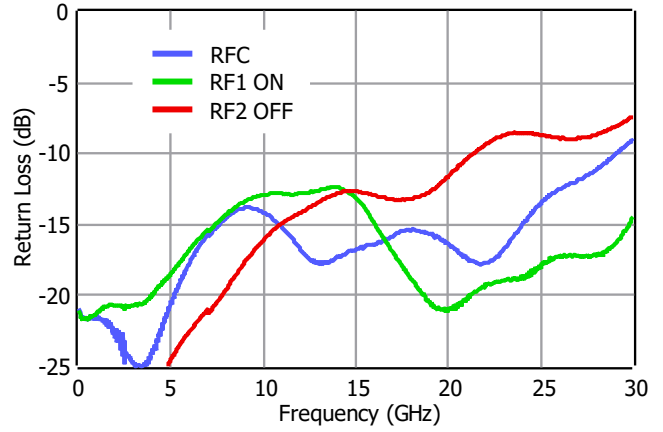

Isolation from RFC to RF2

