



# User Guide

## EVB-ATEK254N3-03

---

Document Code : 023-134201  
Revision No : 01  
Revision Date : 16/06/2022

**Revisions**

Revision No	Revision Date	Revision Reason	Section / Page No
1.0	16.06.2022	Initial Release	

**INDEX**

<b>1</b>	<b>GENERAL INFORMATION .....</b>	<b>3</b>
<b>2</b>	<b>DESIGN INFORMATION .....</b>	<b>4</b>
<b>2.1</b>	<b>SCHEMATIC .....</b>	<b>4</b>
<b>2.2</b>	<b>BOM .....</b>	<b>4</b>
<b>3</b>	<b>TYPICAL PERFORMANCE PLOTS.....</b>	<b>5</b>

1 GENERAL INFORMATION

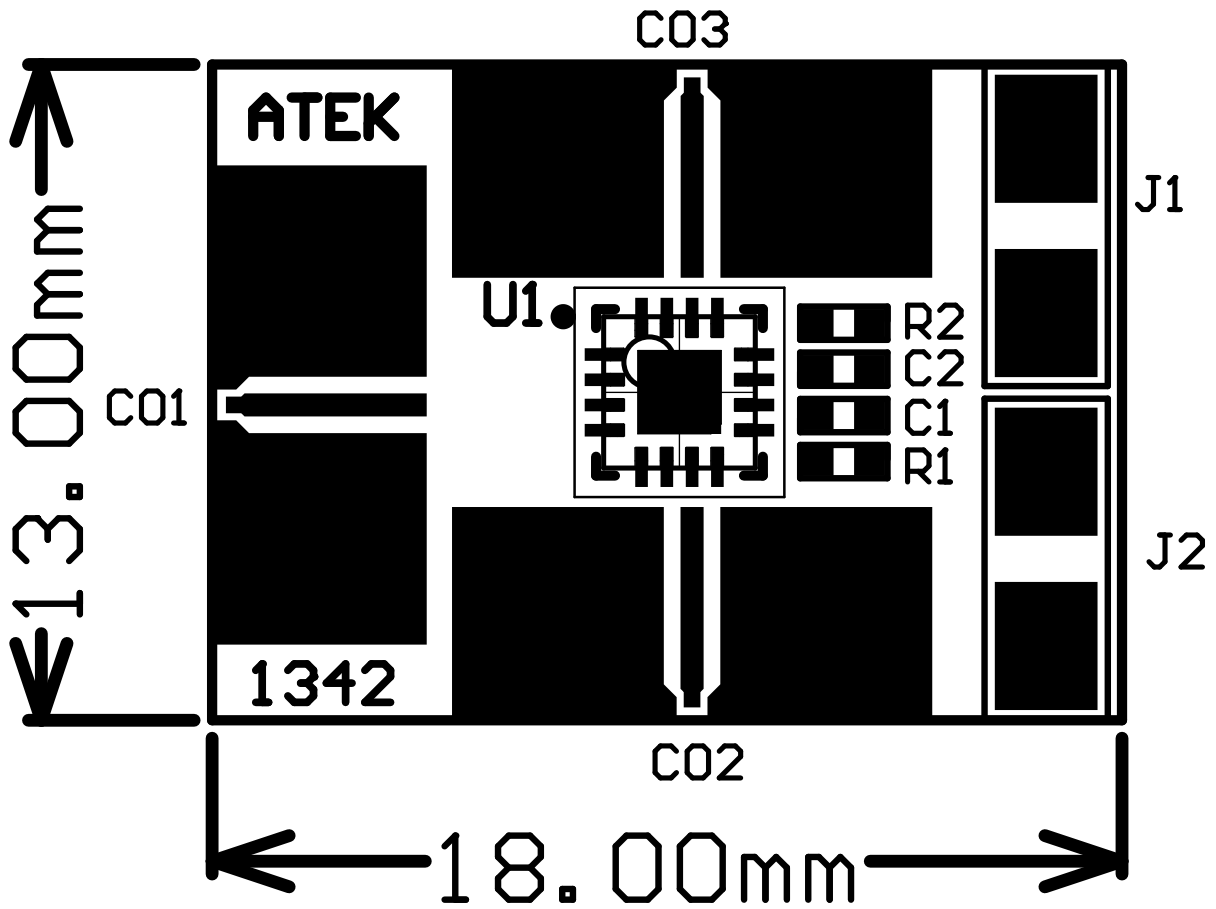

PIN Name	Definition	Comment
C01	N/A	K Connector
C02	RF IN	K Connector
C03	RF OUT	K Connector
J1 Up	CTRL A	2.54mm Header
J1 Down	CTRL B	2.54mm Header
J2 Up	N/A	2.54mm Header
J2 Down	GND	2.54mm Header

Notes:

1. VDD Voltage is detailed in Datasheet.
2. Control Voltages are detailed in Datasheet.
3. The definition of up, down, right, and left is valid for this view of PCB.

2 DESIGN INFORMATION

2.1 SCHEMATIC

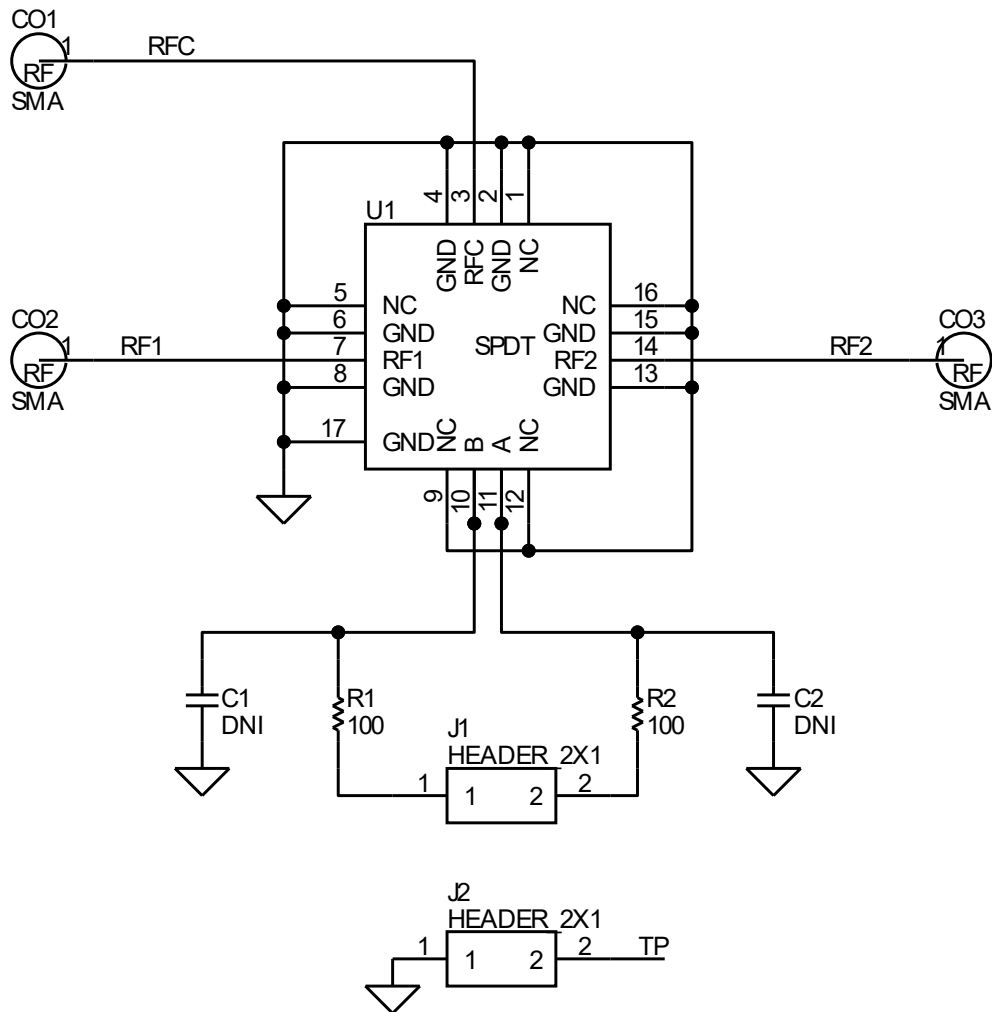

2.2 BOM

Designator	Footprint	Qty	Comment	PN
C1, C2	0402	2	DNP	
CO1	K Connector	1	DNP	
CO2, CO3	K Connector	2	K Connector	ATEK9292
J1, J2	2x1 Header	2	2x1 Header	
R1, R2	0402	2	OR	
U1	ATEKQ3316	1	SPST	ATEK254N3

3 TYPICAL PERFORMANCE PLOTS

Conditions unless otherwise specified:  $V_{CTRL} = 0/-5\text{ V}$ ,  $T = 25\text{ C}$ , CW. For details, please refer to the datasheet.

Insertion Loss

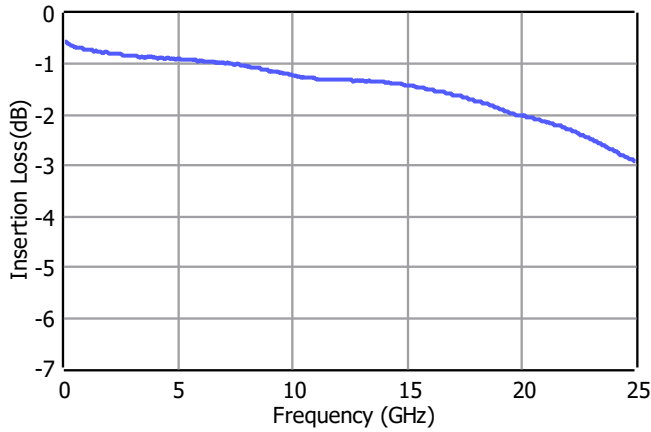

Return Loss

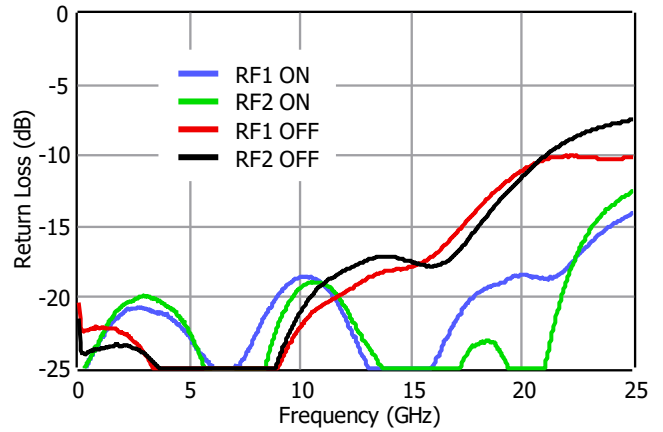

Isolation from RF1 to RF2

