



User Guide

EVB-ATEK258P4-01

Document Code : 023-102201
Revision No : 01
Revision Date : 20/06/2022

Revisions

Revision No	Revision Date	Revision Reason	Section / Page No
1.0	20.06.2022	Initial Release	

INDEX

1	GENERAL INFORMATION	3
2	DESIGN INFORMATION	4
2.1	SCHEMATIC	4
2.2	BOM	4
3	TYPICAL PERFORMANCE PLOTS.....	5

1 GENERAL INFORMATION

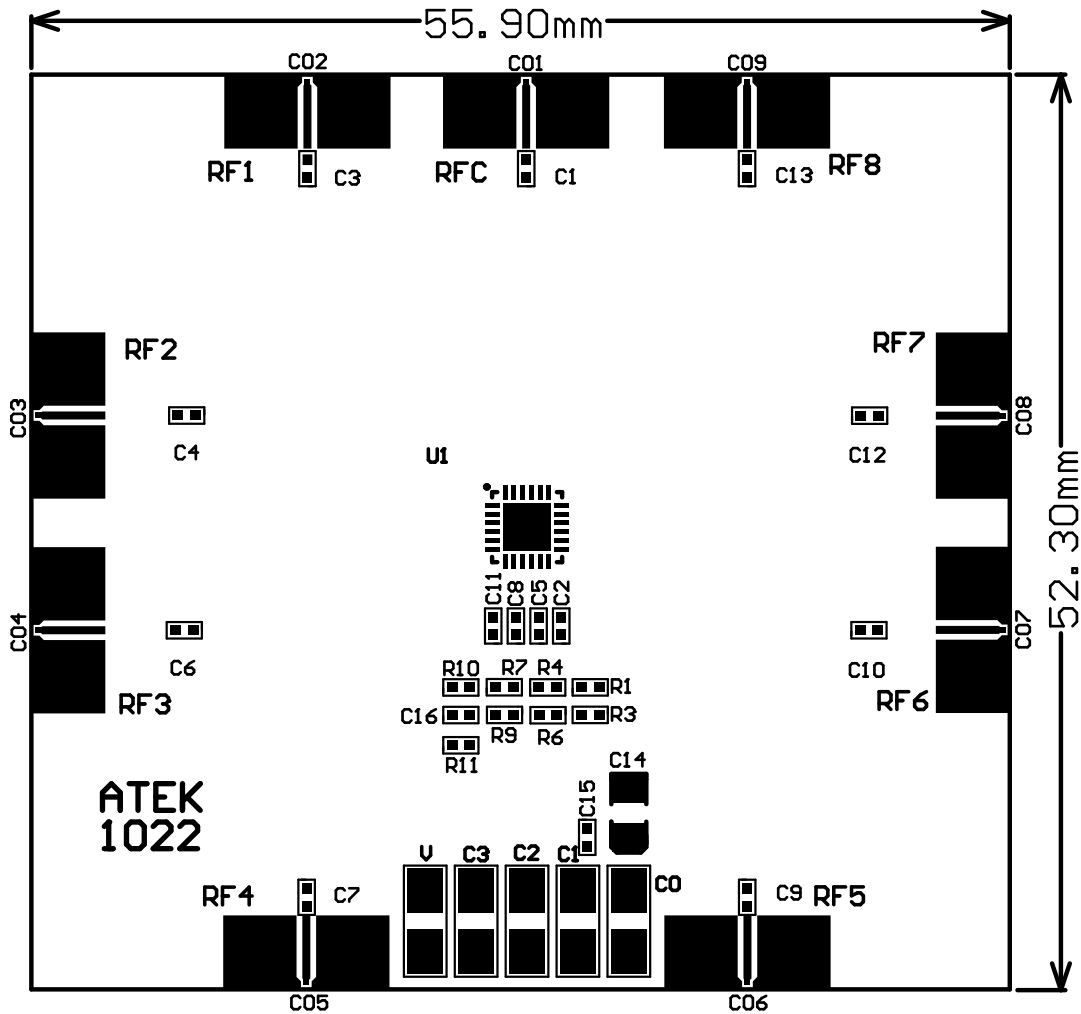

PIN Name	Definition	Comment
CO1	RF IN	SMA Connector
CO2, CO3, CO4, CO5, CO6, CO7, CO8, CO9	RF OUT	SMA Connector
V Up, V Down, C0 Up, C1 Up, C2 Up, C3 Up	VDD	2.54mm Header
C0 Down	GND	2.54mm Header
C1 Down	CTRL A	2.54mm Header
C2 Down	CTRL B	2.54mm Header
C3 Down	CTRL C	2.54mm Header

Notes:

1. VDD Voltage is detailed in Datasheet.
2. Control Voltages are detailed in Datasheet.
3. The definition of up, down, right, and left is valid for this view of PCB.

2 DESIGN INFORMATION

2.1 SCHEMATIC

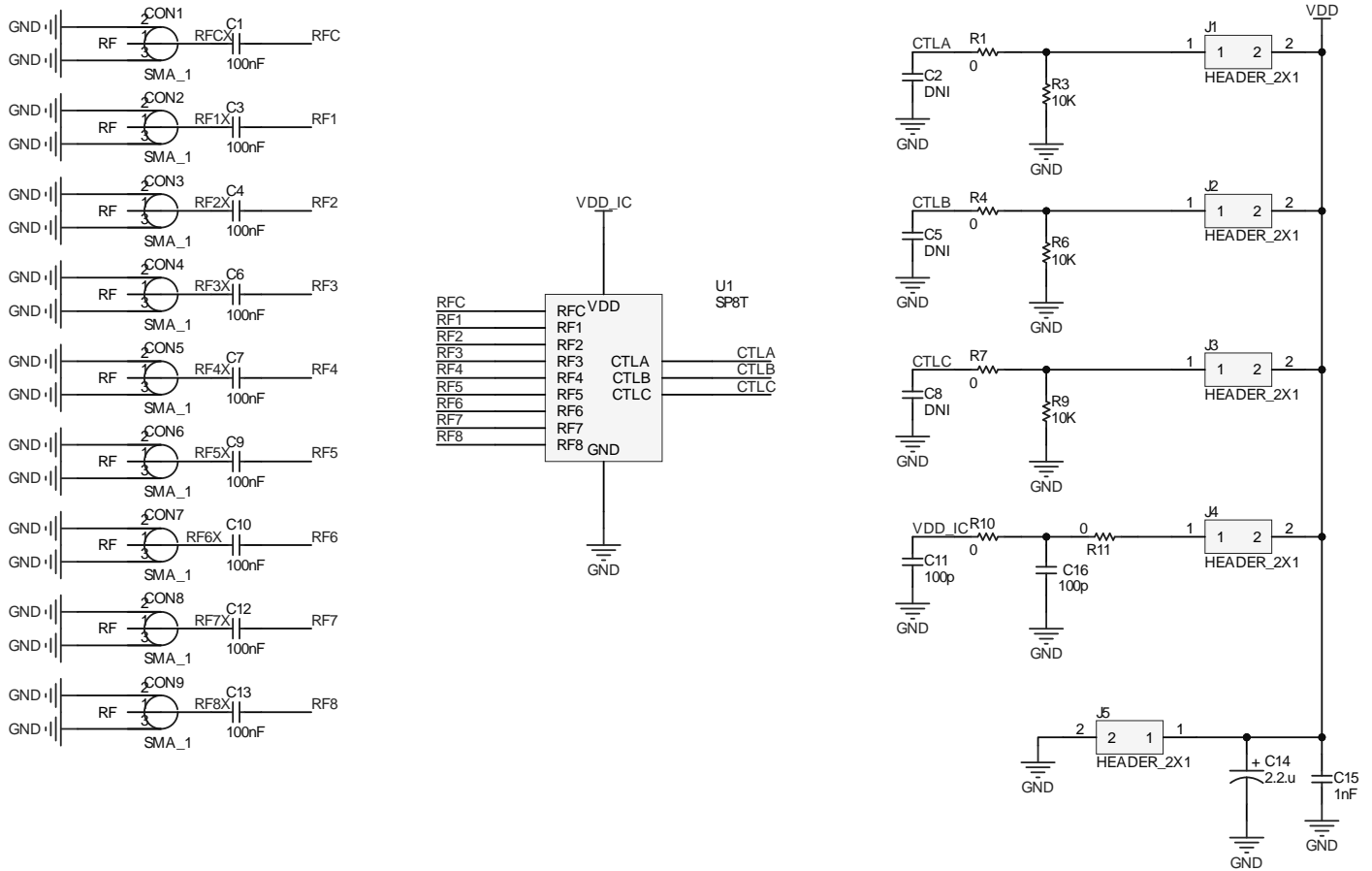

2.2 BOM

Designator	Footprint	Qty	Comment	PN
C1, C3, C4, C6, C7, C9, C10, C12, C13	0402	9	100nF	
C2, C5, C8	0402	3	DNP	
C11, C16	0402	1	100nF	
C14	CASEA	1	2.2uF	
C15	0402	1	1nF	
CO1, CO2, CO3, CO4, CO5, CO6, CO7, CO8, CO9	SMA Connector	9	SMA Connector	
J1, J2, J3, J4, J5	2x1 Header	5	2x1 Header	
R1, R4, R7, R10, R11	0402	5	0R	
R3, R6, R9	0402	3	10k	
U1	ATEKQ4424	1	SP8T	ATEK258P4

3 TYPICAL PERFORMANCE PLOTS

Conditions unless otherwise specified: $V_{CTRL} = 0/5\text{ V}$, $T = 25\text{ C}$, CW. For details, please refer to the datasheet.

Insertion Loss

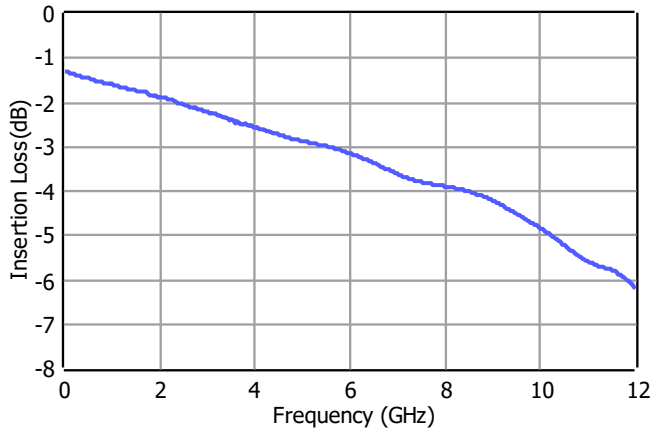

Return Loss

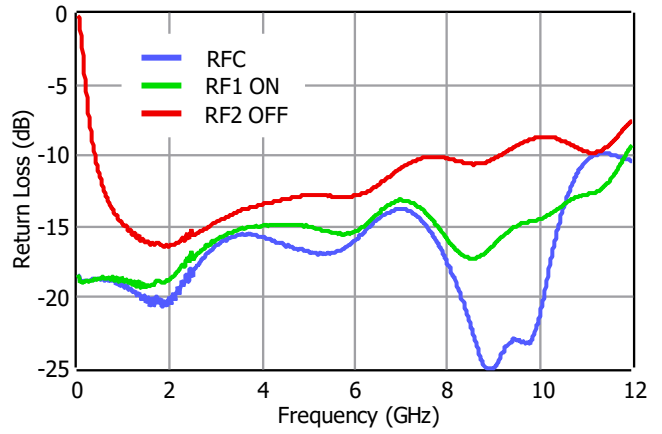

Isolation

